

Leistritz

Precision Carbide Tools

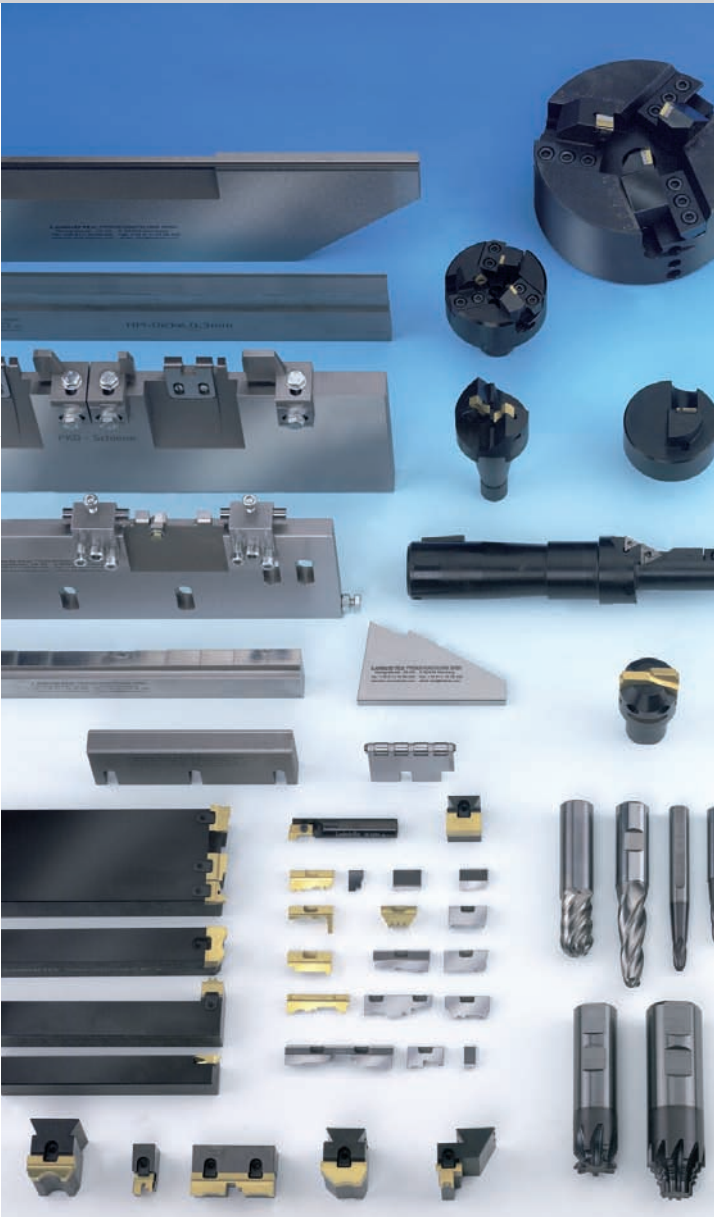

LEISTRITZ PRODUKTIONSTECHNIK GMBH



Leistritz Solide Carbide Precision Tools

The Optimal Cut

**Our Profil-Center produces
new and regrinds:**

- Form End Mills
- Subland Drills
- Form Countersinks
- Ball Nose End Mills
- Die Sinking Cutters
- Core Drills
- Torus Cutters
- Profile Cutters
- Flat Drills
- Forming Punches
and many others

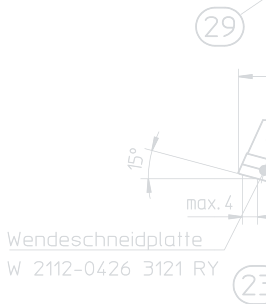
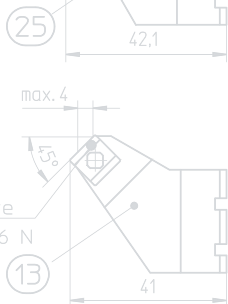

Leistritz End Working Tools

Wendes
W 2112-

The Optimal End of Your Workpiece

The multi function tool system reduces production time Modular constructed tools system ex stock Tool holders radial adjustable Up to 5 cutting operations in one working cycle

endes
2112-

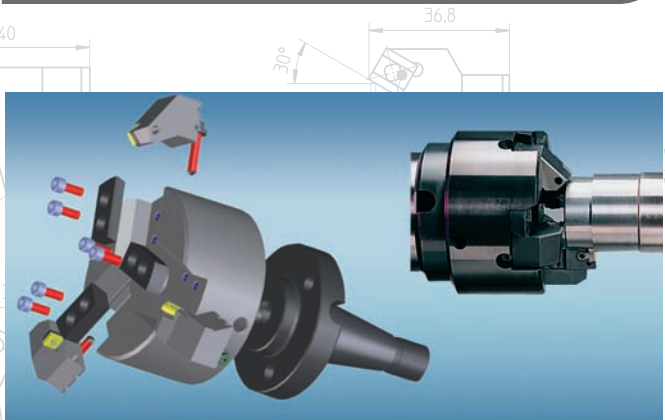

Wende
W 2112



Possible Working Options:

- Facing 37,5
- Chamfering (Internal & External)
- Pointing Turning Outside Diameter
- and many other functions

Wendeschnidplatte
3121 RY

12

44,5

40,7

10°

Leistritz Supporting Bars, Solid Carbide Drilling and Reaming Tools

Well Supported

- Continuous Bars
- Recessing Bars
- Prism Bars
- Guiding Templates
- Clamping Jaws
- Thread Roll Support



New Production, Repairing and Regrinding:

- Supporting bars for all centreless grinding machines
Carbide-tipped, PCD-tipped, Hardened

Solid Carbide Drilling and Reaming Tools

- NC-Reamers
- NC-Machine Reamers
- High Performance Reamers
- Form Reamers
- Core Drills
- Step Drills
- Form Drills
- Flat Drills
- Special Drills





Leistritz Flatform Tools

The Fastest Way to Your Profile – Grooving!

DIN 69893 HSK

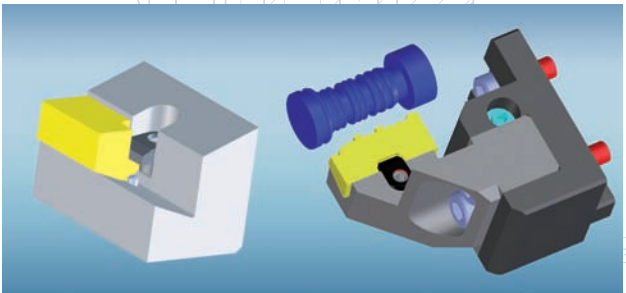
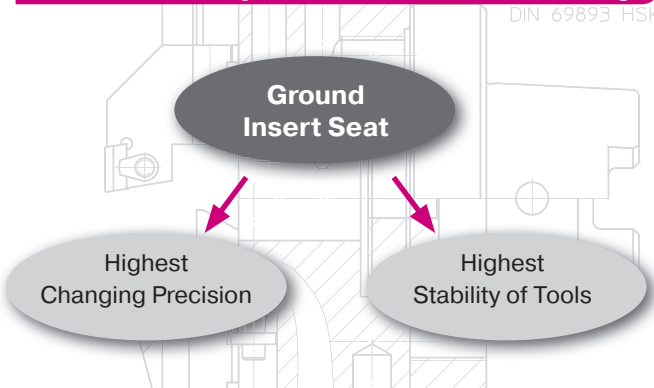

Leistritz-Profil-Center grinds the optimal grooving tool for your production within shortest time.

Many toolholders are in stock. Custom toolholders with short delivery.

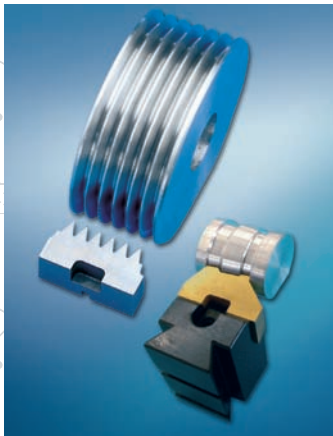

Wendeschneidplatte

max. 4

Wendeschneidplatte

More than 100 Years Experience

Partner for Modern Technology

As producer of carbide precision tools Leistritz has decades of experience in construction and production of special tools.

The latest construction and production equipment guarantee the best tool design and tools of consistent top quality.

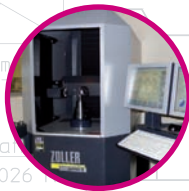

Wendeschneidplatte
W 0809-0000 3026

Wendeschneidplatte

LEISTRITZ PRODUKTIONSTECHNIK GMBH

Markgrafenstr. 29-39

D-90459 Nuremberg

Phone: +49 (0) 911 4306-350

Fax: +49 (0) 911 4306-300

E-Mail: profil-center@leistritz.com

www.leistritz.com