

Leistritz

LEISTRITZ PUMPEN GMBH

Screw Pumps & Systems

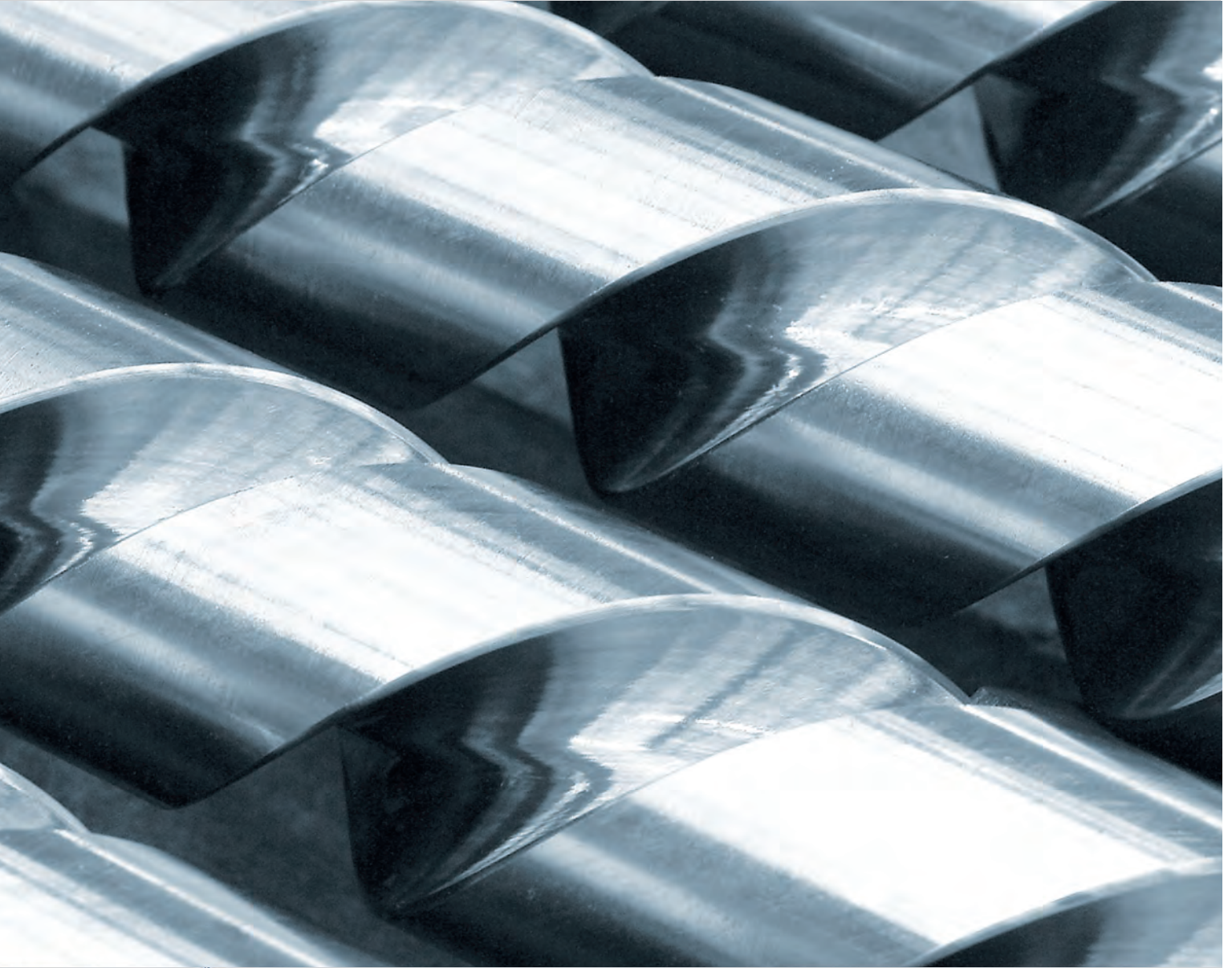

Oil & Gas



Leistritz Screw Pumps and Systems

Leistritz Pumpen GmbH, with its headquarters in Nuremberg/Germany, has been producing Screw Pumps since 1924. The first Leistritz Screw Pump was developed by Paul Leistritz as Main Lube Oil Pump for bearings of steam turbine generator sets.

With the widest product range of Screw Pumps, Leistritz offers today complete pump packages, being a perfect partner for the Oil & Gas sector. Latest technology in combination with strictly controlled quality is the basis for the globally recognized efficiency and reliability of Leistritz Screw Pumps.

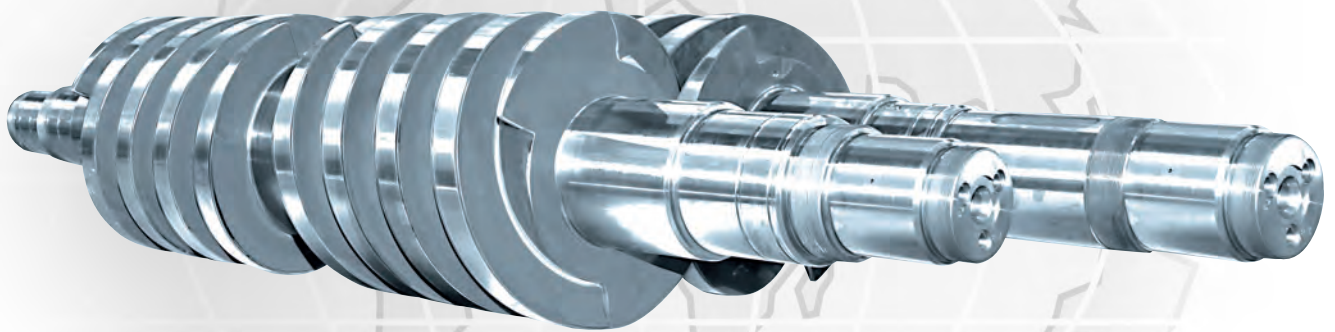

Exploration

Upstream

Production



Pages 4-5

- Multiphase Pumping
- Surface & Subsea
- Chemicals Handling
- Produced Water Treatment
- Slops & Drains Handling

Crude Transfer



Pages 6-7

- Circulation
- Pipeline Start-Up
- Transfer
- Stripping
- Tank Cleaning

Transport & Storage



Pages 8-9

- On-Board Cargo Handling
- Loading
- Unloading
- Boosting
- Onshore Transfer
- Stripping
- Circulation

The Oil & Gas Industry

The Oil & Gas Industry is divided into three major sectors, Exploration, Upstream and Downstream. However, Exploration operations are usually simply included in the Upstream category.

The Upstream sector includes the searching for potential underground or underwater oil and gas fields, drilling of exploratory wells, and subsequently operating the wells that recover and bring crude oil and/or raw natural gas to the surface. Commodities such as crude oil, natural gas and natural gas liquids are stored, marketed and transported before they are treated and converted into the final products.

The Downstream sector includes oil refineries, petrochemical plants, petroleum product distribution, retail outlets and natural gas distribution. The Downstream industry serves consumers with thousands of products such as gasoline, diesel, jet fuel, heating oil, asphalt, lubricants, rubber, plastic and many more.

Screw Pumps are globally used in the Oil & Gas Industry for handling crude oil, emulsions, produced water, multiphase fluids with high gas contents as well as intermediate and final liquid products.

Based on the worldwide largest product range of Twin, Triple and even Five Screw Pumps, Leistritz is serving the Oil & Gas Industry Upstream and Downstream. Today, Pumps and Systems made by Leistritz Pumpen GmbH are charging the pulse-beat of the most modern Oil & Gas processes.



Downstream

Final Consumption

Refineries



Pages 10-11

- Unloading
- Charging
- Residue Handling
- Slops & Drains Handling
- Blending
- Circulation
- Loading

Distribution & Storage



Pages 12-13

- Unloading
- Circulation
- Loading
- Transfer
- Stripping

Special Application



Page 14

- Lubrication
- Sealing



Production

Leistritz Multiphase Pumps and Systems are globally used for handling untreated well flow with gas volume fractions (GVF) between 0 and 100 %, flow rates up to 4000 m³/h and differential pressures up to 100 bar.

With the multiphase pump as the heart of the system, the scope of supply includes skid type baseframes, drivers, instrumentation, on-skid piping with valves, auxiliary systems and control equipment.

The pumps can be driven by electric motors, diesel engines, gas engines or turbines. Leistritz Multiphase Pump Systems are designed to operate under severe ambient conditions in remote locations onshore, on offshore platforms and subsea.

Conventional Concept

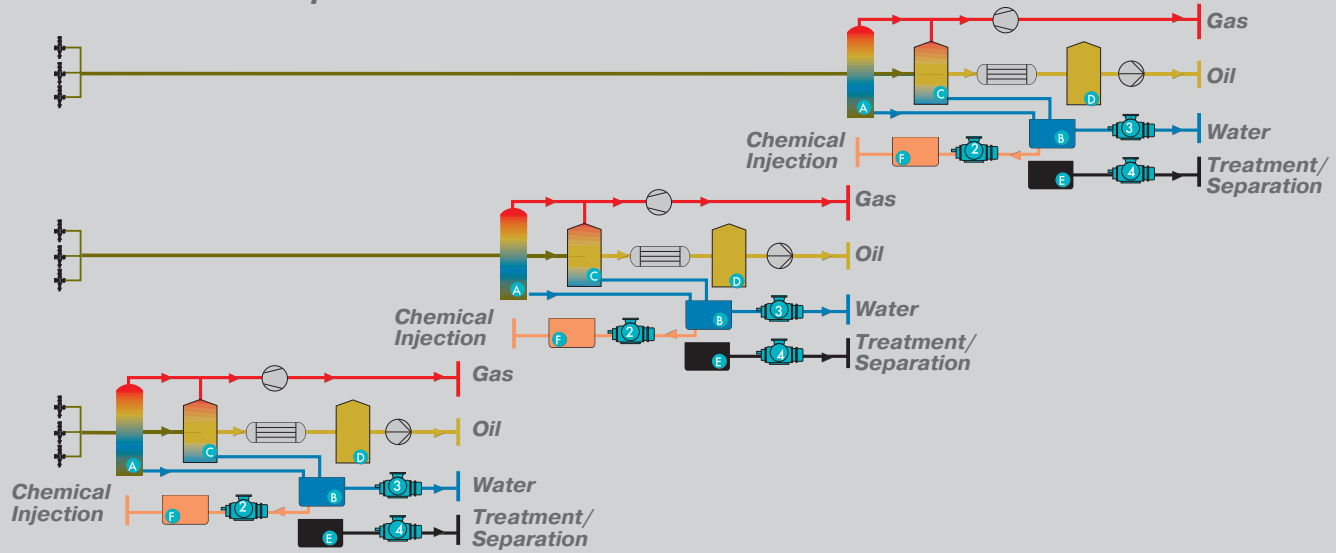

Multiphase Concept

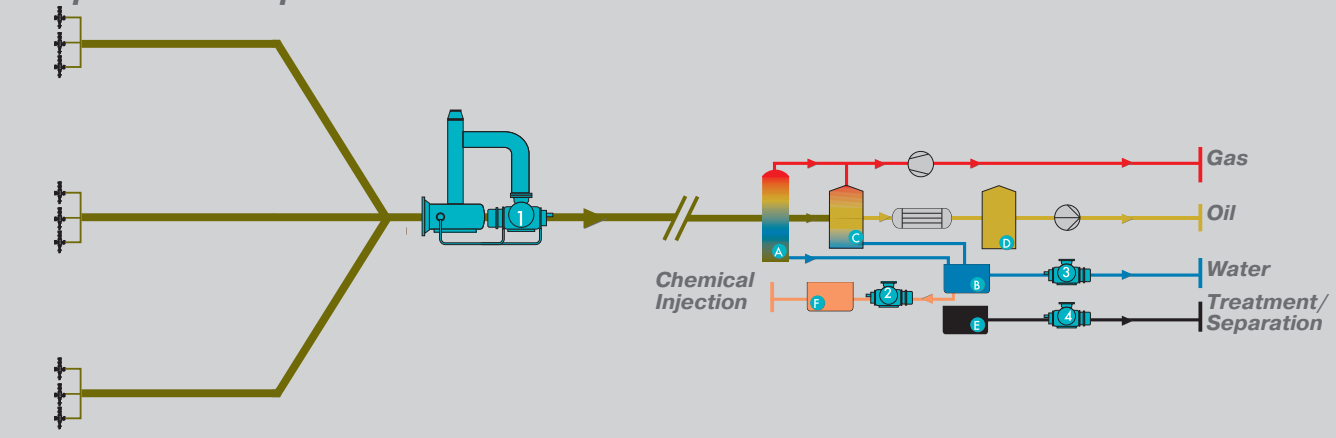

oversimplified illustration

- Multiphase Well Flow
- Oil
- Gas
- Water
- Chemicals
- Slops & Drains

- Heater/Treater
- Export Oil Pump
- Gas Compressor

- 1 Leistritz Multiphase Pump
- 2 Leistritz Chemicals Handling Pump
- 3 Leistritz Produced Water Pump
- 4 Leistritz Slops & Drains Pump

- A Production Separator
- B Water Treatment
- C Wash Tank
- D Crude Oil Storage
- E Slops & Drains Tank
- F Chemical Storage Tank

1 Leistritz Multiphase Booster Pump L4

The untreated well flow is boosted by Leistritz Multiphase Pumps, series L4, to a central treatment facility. With their ability to work at low suction pressure along with a high differential pressure capability, Leistritz Multiphase Pumps are ideal for applications on marginal and declining oil fields. External liquid management systems guarantee trouble-free operation in case of extended slug flow periods.



1 Multiphase Booster Pump L4MK

1 Leistritz Multiphase Pump L4 with Thermal Insulation

Leistritz Multiphase Pumps with insulation are used for applications where the systems are installed outside under severe ambient conditions. The insulation of the pumps, the piping and the instrumentation along with heat tracing ensures trouble-free operation in case of sudden frost or low temperature periods during the winter months.



1 Multiphase Pump L4HK with Thermal Insulation

1 Leistritz Multiphase Pump L4 on Offshore Platforms

Based on their small footprint and low weight, Leistritz Multiphase Pump Systems are particularly suitable for the installation on offshore platforms. The skid design and the arrangement of the accessories can be adapted to the available space on large production platforms or small wellhead platforms.



1 Multiphase Pump L4HK on an Offshore Platform

2 Leistritz Chemicals Handling Pump L4

During the separation, the MEG/TEG is taken out of the gas and re-injected into the well. Leistritz Screw Pumps, series L4, are used in the separation process and for returning the anti-freezers to the injection tank.



2 Chemicals Handling Pump L4NG

3 Leistritz Produced Water Pump L4

Formation water or injected water are usually produced along with oil and gas from a well or well cluster. The so called produced water is separated and treated to minimize the final oil and solids content. Leistritz L4 Pumps are used to re-inject the produced water into the reservoirs to force the oil to the surface.



3 Produced Water Pump L4NG

4 Leistritz Slops & Drains Pump L4

Slop and drain systems are used to collect leakages and drainages from stationary or rotating equipment in upstream production facilities. The systems can be open or closed. Horizontal or vertical Leistritz L4 Pumps are used to transfer these mixtures of water, hydrocarbons and solids to separators or to re-inject into the trunk line.



4 Vertical Slops & Drains Pump L4NT



Crude Transfer



The separated crude is stored on production site before transport. From storage, the crude oil will be either pumped through a pipeline to the refinery or transferred onto ships, railcars or trucks. In order to operate crude storage facilities safe and reliable, Leistriz Screw Pumps are used for crude transport and cleaning.

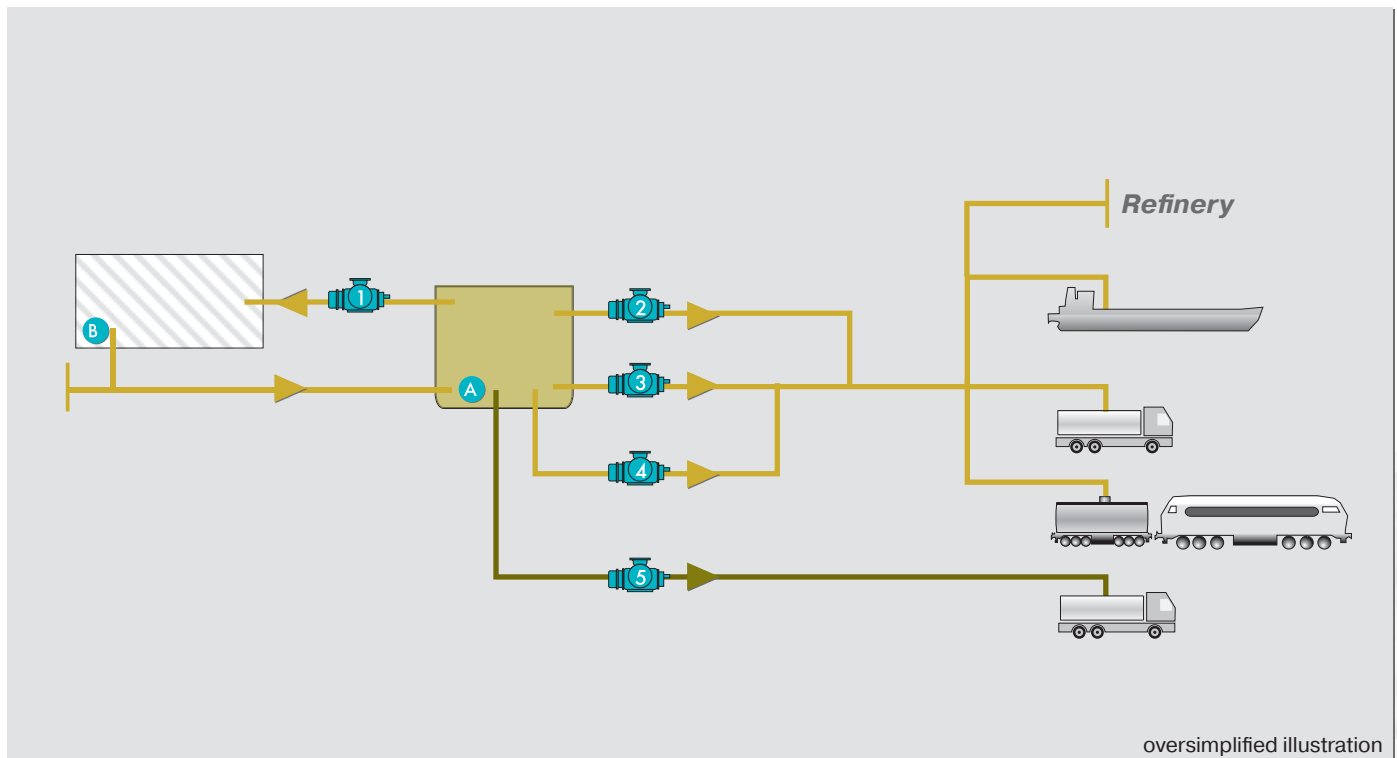

— Crude Oil
— Residue

- ① Leistriz Crude Circulation Pump
- ② Leistriz Pipeline Start-Up Pump
- ③ Leistriz Crude Transfer Pump
- ④ Leistriz Crude Stripping Pump
- ⑤ Leistriz Tank Cleaning Pump

- Ⓐ Storage Tank
- Ⓑ Production Process

oversimplified illustration

1 Leistritz Crude Circulation Pumps L3 and L4

Settlement of wax and other substances on the inside surface is reducing the nominal diameter of crude oil pipelines on production side. Leistritz Screw Pumps are employed to flush the pipework with crude oil from the storage tanks on a regular base. Beside Leistritz L4-series Pumps, L3-series with screws and liners of special design are used in many applications.

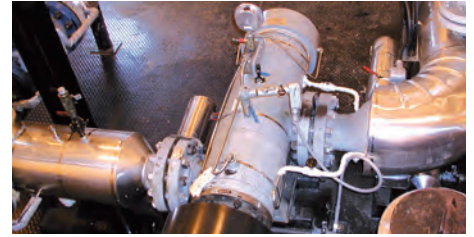

1 Crude Circulation Pump L3HG

2 Leistritz Pipeline Start-Up Pumps L3 and L4

High pressure Triple Screw Pumps, series L3, or high pressure Twin Screw Pumps, series L4, are installed as pipeline start-up pumps. These pumps are required when the main pipeline pumps cannot overcome the friction losses during start-up of a crude oil pipeline. Leistritz serves applications with up to 100 bar boost pressure.



2 Pipeline Start-Up Pump L4HK

3 Leistritz Crude Transfer Pumps L2, L3 and L4

For pumping crude oil through pipelines to a refinery or to ships, railcars or trucks, crude oil transfer pumps are required. Leistritz Screw Pumps are capable of handling wide viscosity and pressure ranges at flow rates up to 4000 m³/h. Screw Pumps, series L4, are typically used as crude oil transfer pumps. L3-series Triple Screw Pumps and L2-series Twin Screw Pumps are used for special transfer applications.



3 Crude Transfer Pumps L2NG

4 Leistritz Crude Stripping Pump L4

Large crude oil transfer pumps with big port sizes are not particularly suited to empty storage tanks completely. Smaller Leistritz Screw Pumps, series L4, either in submerged design or dry mounted, must be used. With their excellent suction capability they remove heavy products with high viscosity and high solids content from the bottoms of the storage tanks. A special screw design along with a wide range speed control reduce the NPSH_R values of these pumps to a minimum.



4 Crude Stripping Pump L4NG

5 Leistritz Tank Cleaning Pump L4

Crude oil storage tanks must be cleaned on a regular base. Leistritz Screw Pumps, series L4, handle these often high viscous residues consisting of heavy oil sludge and solids. Special Tungsten Carbide coating of the screws and Stellite coating on the liners protect the pumps against excessive wear and increase the service life considerably.



5 Tank Cleaning Pump L4NG



Transport & Storage



The crude oil must be transported from the production site to the final destination or refinery. This is usually done by pipelines using booster pumps and pump stations. Alternatively the crude can be transported by ship, truck or railcar if no direct connection to the refinery is available. In those cases the crude oil is stored for short time before being finally shipped/transported.

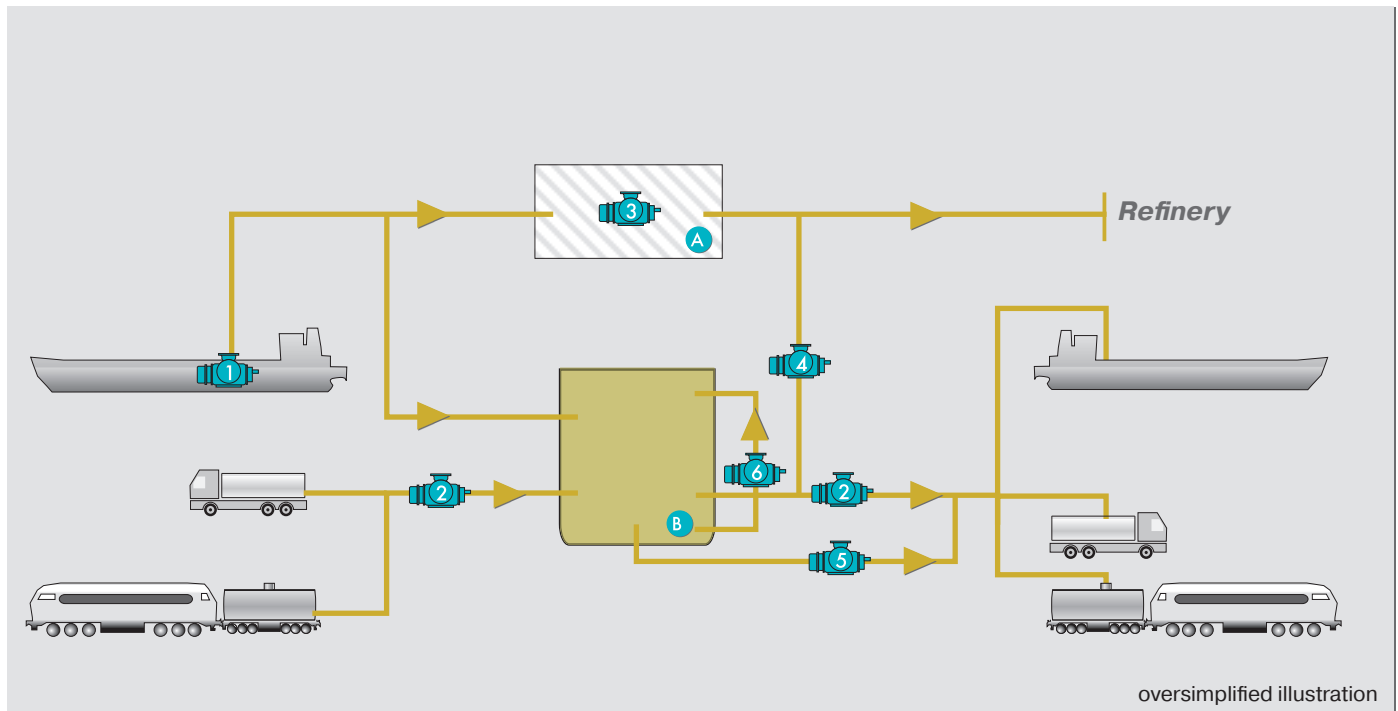

— Crude Oil

- ① Leistriz On-Board Crude Cargo Pump
- ② Leistriz Crude Loading/Unloading Pump
- ③ Leistriz Crude Booster Pump
- ④ Leistriz Onshore Crude Transfer Pump
- ⑤ Leistriz Crude Stripping Pump
- ⑥ Leistriz Crude Circulation Pump
- A Booster Pump Station
- B Storage Tank

1 Leistritz On-Board Crude Cargo Pumps L4 and L5

Different unrefined crude oils are handled by Leistritz Screw Pumps. Leistritz L4- and L5-series Pumps are typically used. They are available in submersible design or as deck mounted units. They can also operate as stripping pumps.



1 Crude Cargo Pump L4NG

2 Leistritz Crude Loading/Unloading Pumps L2, L4 and L5

Loading and unloading of crude oil from trucks, railcars or ships are typical applications for Leistritz Screw Pumps, series L2, L4 and L5. These pumps have the ability to run dry (L2 and L5 with time limitation). They are self-priming and can handle a certain amount of solids.



2 Crude Unloading Pump L2NG

3 Leistritz Crude Booster Pump L3

Leistritz high pressure Triple Screw Pumps, series L3, are well suited for pipeline booster applications in pumping stations. Due to their design, the pumps can handle crude oil with a wide range of viscosities and generate high differential pressures even when pumping very light crudes.



3 Crude Booster Pump L3HG

4 Leistritz Onshore Crude Transfer Pumps L3, L4 and L5

Leistritz Screw Pumps, series L3, are used to transfer both light and heavy crude oil to different storage facilities. L4- and L5-series Pumps are installed for higher flow rates up to 4000 m³/h.



4 Crude Transfer Pump L3MG

5 Leistritz Crude Stripping Pump L4

The product remaining on the bottom of the crude storage tanks is normally heavy, high viscous and contains solids. Low speed Leistritz Screw Pumps, series L4, with excellent suction capabilities and the ability to run dry are preferred for tank stripping. Variable speed operation along with a special screw design guarantee excellent NPSH_R values.



5 Crude Stripping Pump L4NG

6 Leistritz Crude Circulation Pumps L2, L3 and L4

The crude oil stored in the tanks must be circulated to avoid separation and to maintain the temperature. Additionally, the system pipework must be regularly flushed to prevent the adhesion of wax or other substances reducing the nominal diameter. Leistritz Screw Pumps, series L2, L3 and L4, are used to circulate the product through the system pipework and/or heaters.



6 Crude Circulation Pump L4NG



Refineries



The unprocessed crude oil has to be refined into consumable petroleum products. These refined products are usually grouped into three categories:

Light distillates (LPG, gasoline, naphtha), medium distillates (kerosene, diesel) and heavy distillates/residues (fuel oil, lubricating oils, wax, tar). From unloading the unprocessed crude to loading of the final products, Leistritz Screw Pumps are operating in various services in oil refineries.

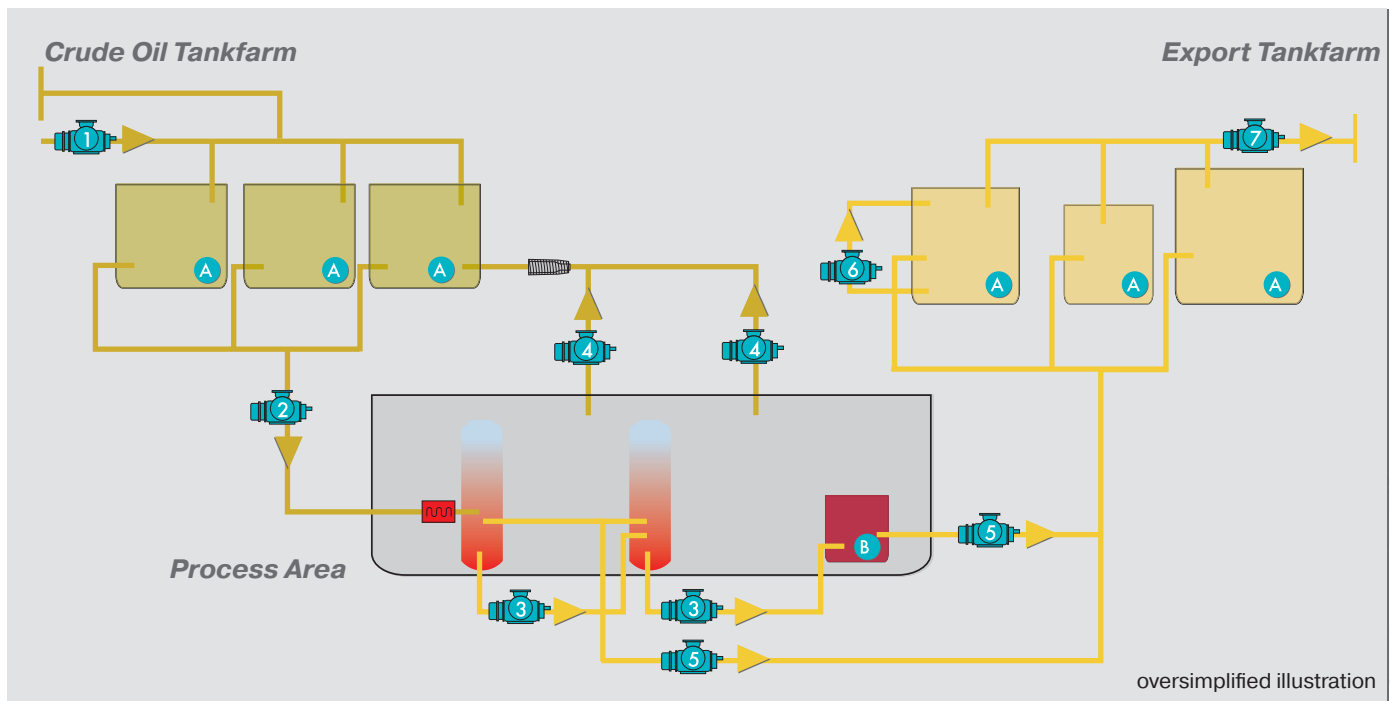

- Crude Oil
- Final Product
- Separator
- Heat Exchanger

- 1 Leistritz Crude Unloading Pump
- 2 Leistritz Crude Charging Pump
- 3 Leistritz Atmospheric Tank Bottoms / Vacuum Residue Pump
- 4 Leistritz Slops & Drains Oil Pump
- 5 Leistritz Blending / Final Product Transfer Pump
- 6 Leistritz Circulation Pump
- 7 Leistritz Loading Pump

- A Storage Tank
- B De-Asphalting Unit



1 Leistritz Crude Unloading and

7 Final Product Loading Pumps L2 and L4

Various types of crude oil must be unloaded from railcars or pumped from the onshore production site to the refinery. The final products are loaded onto ships, railcars or trucks. For both services Leistritz Twin Screw Pumps, series L2 and L4, are the preferred choice because of their high flow rates and self-priming, dry-running and solids handling capabilities.

2 Leistritz Crude Charging Pumps L2 and L4

Leistritz Screw Pumps transfer and charge the crude oil to the various processes of the refinery. All Leistritz Screw Pump series can be used, however, Twin Screw Pumps of the L2- and L4-series are preferably used because of their ability to handle larger solids in the product, which offers an extended MTBF.

3 Leistritz Atmospheric Tank Bottoms / Vacuum Residue Pump L4

The tank bottoms from the atmospheric distillation vessel must be transported to the vacuum distillation vessel. After distillation the vacuum residues are transferred to the de-asphalting process for the production of asphalt, bitumen, wax and fuel oil. These hot bottoms and residues are usually pumped with Leistritz Screw Pumps, series L4, which are designed to handle large solids at temperatures up to 320°C. The low NPSHR values of the Leistritz Twin Screw Pumps, series L4, allow a higher reactor vacuum and hence, an improved reactor efficiency.

4 Leistritz Slops & Drains Oil Pumps L2 and L4

Various drains and waste hydrocarbons must be pumped to the separator station of a refinery. All Leistritz Screw Pump series can be used. Twin Screw Pumps of the L2- and L4-series are primarily installed because of their solids handling abilities.

5 Leistritz Blending / Final Product Transfer Pumps L2 and L4

The clean or blended refined products are transferred to the export tanks. High viscous liquids as heavy fuel oil, paraffin, wax, asphalt, bitumen, base oil and molten sulphur as well as light products are handled by Leistritz Screw Pumps of all series. Twin Screw Pumps of the L2- and L4-series are mainly used because they tolerate large solids in the pumped product, which offers an extended MTBF.

6 Leistritz Circulation Pumps L2 and L4

Particularly high viscous products (e.g. asphalt/bitumen) have to be circulated in the storage tank to guarantee homogeneous product quality in all tank levels. The circulation of these hot, viscous hydrocarbons is usually done by Leistritz Twin Screw Pumps, series L2 and L4.



1 7 Unloading and Loading L4NG



2 Crude Charging Pump L4NG



3 Vacuum Residue Pump L4MG



4 Slops & Drains Oil Pumps L2NG



5 HFO Blending Pump L2NG



6 Bitumen Circulation Pump L2NG



Distribution & Storage



To link Upstream facilities, where mainly natural resources are explored and produced, with Downstream facilities like refineries or petrochemical plants and final distribution, Transport & Storage of a large variety of Oil & Gas products is required. Rising domestic energy consumptions versus only single resourcing spots make it necessary to have Distribution & Storage facilities which could serve worldwide demands. Oil trading centers and international petrochemical hubs are usually large oil storage capacities as a basis of global Oil & Gas logistics.

Leistriz Screw Pumps are used in various worldwide operating tank terminals. Special low pulsation and low NPSH profiles of the internal rotating parts combined with the typical character of positive displacement pumps like the proportional dependence of pump speed and capacity makes Leistriz Screw Pumps the ideal partner for terminal operations.

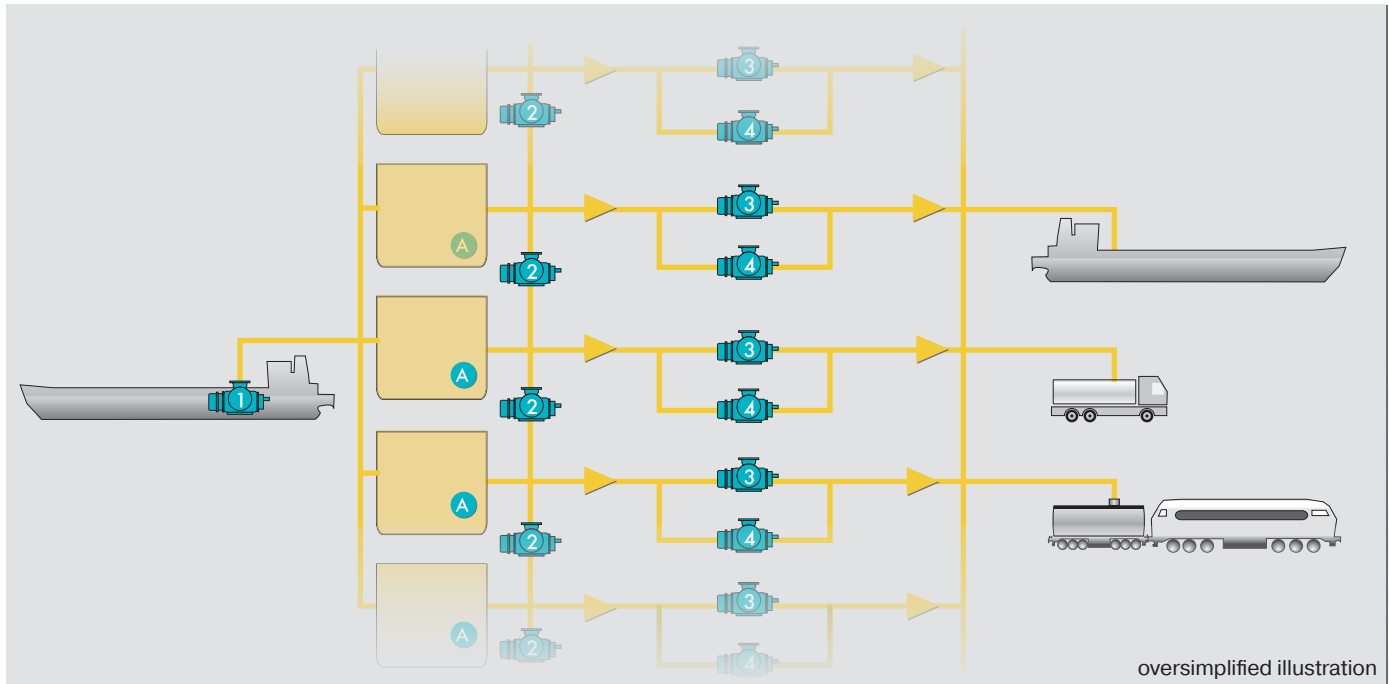

— Crude & Refined Product

- 1 Leistriz On-Board Unloading Pump
- 2 Leistriz Circulation Pump
- 3 Leistriz Loading Pump
- 4 Leistriz Stripping Pump

A Storage Tank



1 Leistritz On-Board Unloading Pump L4

Various types of oil products are unloaded from ships, railcars and trucks. The preferred pump for these applications is the Leistritz L4-series with the capability of handling large solid particles contained in the pumped products. The pumps are operating with nitrided screws manufactured from single piece bar stock, which offer an excellent service life. The pump liner is replaceable.



1 On-Board Unloading Pump L4MG

2 Leistritz Circulation Pump L4

It is particularly important to maintain a homogeneous product quality with constant viscosity over the entire tank volume. To reach this target, Leistritz Screw Pumps, series L4, are installed for the circulation of the stored tank products.



2 Circulation Pump L4MG

3 Leistritz Loading and Transfer Pump L4

A variety of oil based products are transferred from the storage tanks to ships, railcars and trucks for transportation to the end users. Leistritz Screw Pumps, series L4, with their excellent suction capability and low pulsation are used in these applications. The pumps handle viscosities up to more than 3000 mm²/s. A special screw design guarantees very low NPSHR values. Flow rates up to 5000 m³/h permit short loading periods resulting in low port fees for ocean going vessels.



3 Loading and Transfer Pump L4NG

4 Leistritz Stripping Pump L4

The product remaining on the bottom of the storage tanks is normally heavy, high viscous and contains solids. Low speed Leistritz Screw Pumps, series L4, with excellent suction capabilities and the ability to run dry are preferred for tank stripping. Variable speed operation along with a special screw design guarantee excellent NPSHR values.



4 Stripping Pump L4NG



Special Application



1 Compressor Lube and Seal Oil Pump L3

1 Leistritz Screw Pump L3 for Gas Compressors

Produced gas must be moved from the production site to the final consumer. Large compressors are used for this service. For their lubrication and sealing systems, Leistritz Screw Pumps, series L3, are the preferred choice.



2 Auxiliary Lube Oil Pump L3MF

2 Leistritz Main Lube Oil-, Auxiliary Lube Oil- and Emergency Lube Oil Pumps L2 and L3

All types of compressors need constantly sufficient lubrication. Leistritz Twin Screw Pumps, series L2 and Triple Screw Pumps, series L3, are installed as compressor lube oil pumps.

Semi-submersible pump designs or dry mounted versions on common lube oil consoles are available in API or non-API versions.



3 Reduction Gear Lube Oil Pump L3MG

3 Leistritz Reduction Gear Lube Oil Pumps L2 and L3

Reduction gears are installed to adapt the speed between compressors and their drives.

Leistritz Triple Screw Pumps, series L3N/M, and Leistritz Twin Screw Pumps, series L2, are used for lubrication of the reduction gears.



4 Seal Oil Pump L3HF

4 Leistritz Seal Oil Pump L3

All compressors have to be sealed against gas leakage. In case of oil lubricated mechanical seals Leistritz Triple Screw Pumps, series L3M/H, are used to transport seal oil.

Customer Service - Pump Test Field - Quality Assurance

Customer Service

Leistritz Screw Pumps are products of continuous customer oriented optimization and development. Professional Leistritz Customer Service is based on worldwide, close and long term partnership with engineers, operators and endusers. Leistritz performs:

- Inspection, Maintenance and Repair
- Service and Maintenance Contracts
- Installation, Commissioning and Retrofits
- Delivery and Installation of Genuine Leistritz Spare Parts
- Training
- Pump Operations under Test Conditions
- Project Supervision
- 24h Service



Leistritz Overhaul Team



Professional Site Inspection



Leistritz Multiphase Test Field



Leistritz Certificates



Monitoring of all Manufacturing Processes

Test Fields

Oil- and Water- Test Fields for individual parameter check and control

- 5 Test Stands
- 4 MW Test Field
- Computer Controlled Recording of Measurement Reading
- Large Volume Tanks for Long Test Periods

Quality Assurance

Latest technology in combination with strictly controlled quality is the basis for the world-wide known Leistritz Screw Pump reliability and efficiency. Leistritz Quality Assurance concentrates on compliance with highest quality standards, e.g.:

- Use of Latest CMM Technology
- Constant Monitoring of all Manufacturing Processes for Small Tolerances
- Strict Tolerance Compliances for High Pump Efficiency and Low Life Cycle Costs
- Know-How-Transfer Due to Close Collaboration with Universities and Independent Institutes

Certificates

Leistritz Pumpen GmbH is Certified According to:

- DIN EN ISO 9001:2000
- DIN EN ISO 14001:2005
- OHSAS 18001
- RS Supervisor
- ROSTECHNADZOR
- GOST-R
- GOST-K

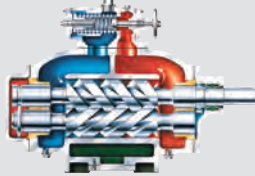
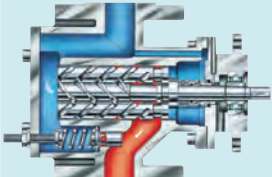
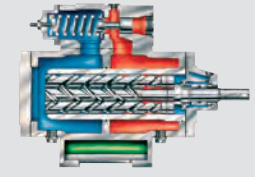
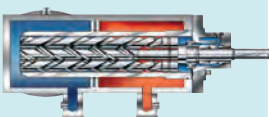
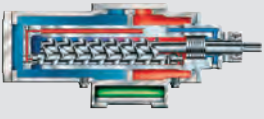
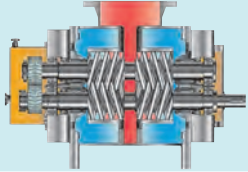
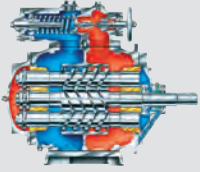

Leistritz Screw Pumps and Systems

Series	Use for	Leistritz Screw Pump	Maximal Performance Data			
			Capacity	Differential Pressure	Viscosity	Pumping Temperature
L2	Low pressure duty, suitable for transport of light abrasive and corrosive, high or low viscous fluids with poor or good lubricity.		900 m ³ /h [3,960 gpm]	16 bar [232 psi]	100,000 cSt	280°C [536°F]
L3N	Low pressure duty, suitable for transport of non abrasive lubricating fluids.		700 m ³ /h [3,100 gpm]	16 bar [232 psi]	15,000 cSt	180°C [356°F]
L3M	Medium pressure duty, suitable for transport of non abrasive lubricating fluids.		300 m ³ /h [1,320 gpm]	80 bar [1,160 psi]	10,000 cSt	280°C [536°F]
L3H	High pressure duty, suitable for transport of non abrasive lubricating fluids.		200 m ³ /h [880 gpm]	160 bar [2,320 psi]	10,000 cSt	280°C [536°F]
L3V/U	Ultra high pressure duty suitable for transport of light abrasive and corrosive, high or low viscous fluids with poor or good lubricity.		180 m ³ /h [792 gpm]	280 bar [4,060 psi]	1,000 cSt	280°C [536°F]
L4	Low, medium and high pressure duty, suitable for transport of abrasive/non abrasive, corrosive/non corrosive, lubricating/non lubricating, high or low viscous fluids.		5,000 m ³ /h [22,000 gpm]	150 bar [2,175 psi]	150,000 cSt	350°C [662°F]
L5	Low pressure duty, suitable for transport of light abrasive and corrosive, high or low viscous fluids with poor or good lubricity.		1,700 m ³ /h [7,500 gpm]	10 bar [145 psi]	100,000 cSt	280°C [536°F]

1.2 - 32 e 01/11 2' tü

LEISTRITZ PUMPEN GMBH
 Markgrafenstrasse 29-39
 D-90459 Nuernberg
 Germany
 Phone: +49 (0)911/4306 - 0
 Fax: +49 (0)911/4306 - 490
 E-Mail: pumpen@leistritz.com
www.leistritz.com

LEISTRITZ ITALIA SRL
 Via dei Fontanili, 26
 I-20141 Milan
 Italy
 Phone: +39 02 84477 451
 +39 02 84477 505
 Fax: +39 02 84477 444
 E-Mail: pompeitalia@leistritz.com

Exceeding operating conditions upon request.

Your Leistritz Partner